

SCHMEISER QUAD-PLANE

ASSEMBLY & PARTS MANUAL



T.G. SCHMEISER CO., INC.

P.O. BOX 1047 FRESNO, CA. 93714
(559) 268-8128 FAX (559) 268-3279

VERSION 1.21

Blank Page

INTRODUCTION

Your Schmeiser Land Leveler is designed to give you many years of dependable service. This manual has been prepared to instruct you in the safe and efficient operation of this machine. Read and study it thoroughly. Follow all instructions carefully.

Should your Land Leveler require replacement parts, go to your Schmeiser dealer. Always order genuine Schmeiser replacement parts.

It is important you complete and send in your Warranty Card because it is not valid unless it is on file at Schmeiser. If you need information not contained in this manual, contact your Schmeiser dealer.

Space has been provided below for you to record your model number and serial number of your leveler. Be sure to bring this information with you to your dealer when ordering parts or attachments for your leveler.

Thank you for buying a Schmeiser Land Leveler.

Serial Number _____

Model Number _____

Date Purchased _____

Dealer Name _____

Blank Page

TABLE OF CONTENTS

Introduction.....	A
Table of Contents.....	B
Set Up Instructions.....	1
Quad Plane Road Transport.....	7
Quad Plane Land Leveling.....	7
Hydraulic Cylinder Option.....	8
Complete Assembly.....	10
Bucket Assembly.....	11
Bucket Bolt-Up Assembly.....	14
Bucket Linkage Assembly.....	16
Tongue Assembly.....	18
Turnbuckle Assembly.....	20
Steel Wheel Assembly.....	22
Tire Axle Assembly.....	24
Tire Axle Hydraulic System Assembly.....	26
Hydraulic Bucket Lift System Assembly.....	28
Hydraulic Cylinder Diagram.....	30
Main Frame Tie Bar Assembly.....	31
Warranty.....	32

Blank Page

QUAD PLANE 40 SET UP INSTRUCTIONS

THE FOLLOWING TOOLS ARE NEEDED:

1. Truck with lifting boom, overhead hoist or forklift with 2000 pound lifting capacity.
2. A 24" adjustable wrench or large pipe wrench.
3. One 6" and two 12" adjustable wrenches.
4. Socket wrench with 15/16" and 1-1/2" sockets.
5. Heavy duty pliers.
6. A heavy duty 12" screwdriver.
7. A 14" tapered drift punch.
8. A pry bar.
9. A medium size ballpeen hammer.
10. A ten pound sledge hammer.
11. Grease gun.

PROCEDURE:

1. Select a smooth level piece of ground approximately 60' x 100' to assemble the SCHMEISER landleveler. Place the bucket, with the bucket cross brace attached, in the center of the level piece of ground and facing the direction in which the machine is to be pulled. Place a wooden block (2" x 6" or 2" x 8" approximately 24" long) under each bucket side plate to prevent sinking and place at least one or preferably two column supports under the bucket cross member to hold it in position for bolting to the main frame.
2. Place the rear cross frame approximately 20 feet in back of the bucket and turn the wheels so they are parallel to the cross frame; then the unit will stand without additional support.

3. Place the front main frame assembly in front of the bucket and rear main frame on the right side of the bucket (standing behind the bucket looking forward) flat and on two pieces of wood (2" x 6" or 2" x 8" approximately 36" long) under each main frame, one near each end. Place the main frame with the front steel wheels attached to it toward the front and with the butt or large end about even with the bucket roll. Place the right rear main frame butt to butt with the right side of the front main frame. Slide together. Line up the mating holes and install (2) 1-1/4" NC x 4-1/2" Gr.8 bolts with lock washers & hex nuts and (1) 5/8" NC x 2" bolt with lock washer and hex nut in the hole near the bottom 1-1/4" NC bolt. Tighten all three.
4. Attach chain or sling to the bolted right main frames. Hoist the main frames up and position them over the bucket and bucket cross brace right end. Line up the mating holes of the bucket cross brace and the main frame mounting plate. Install four 5/8" NC x 4-1/2" bolts, lock washers and hex nuts; snug up with wrench but do not tighten. Place one assembly stand under the bucket cross brace as close to the attached main frame as possible and one assembly stand under the back end of the main frame just high enough that the rear cross frame can be attached.
5. Position the rear cross frame against the flat plate on the rear end of the main frame. Adjust the main frame height (if necessary) so that the saddle clamp can be placed around the rear cross frame tube and bolts can be inserted through the tubes of the saddle clamp and the four mating holes in the end plate of the rear main frame. Insert four 3/4" NC x 3" bolts, lock washers and hex nuts. Snug up but do not tighten. It must be loose enough to move for sideways adjustment.
6. Hoist the center cross frame up with sling or chain attached to the 3" x 3" tube so that the cross frame is parallel to the ground and oriented to the square hole in the upper middle section of the right main frame. Make sure the cross frame is positioned so that the attaching bracket on the bottom side of the 3" x 3" square tube is flush on the side facing the forward end of the machine. Now slide the end of the square tube through the square hole in the frame until the two attaching holes match up. Install one 1" x 3-1/2" bolt with lock washer and hex nut and one 5/8" x 2" bolt with lock washer and hex nuts. Tighten securely. Place an assembly stand under the center cross frame base angle to support it in a level position.
7. Place the left rear main frame on the left side of the bucket and repeat the assembly procedure of Step 3 to

assemble the left main frames.

8. Attach a chain or sling to the bolted left main frames. Hoist them up, line the square hole in the frame up with the 3" x 3" square tube of the center cross frame. Slide the frame onto the tube until the 1" NC x 3-1/2" bolt can be installed through the tube and the hole in the butt plate. Install the lock washer and hex nut. Snug up only, do not tighten.
9. Align the main frame over the bucket cross brace matching the holes. Install four 5/8" NC x 4-1/2" bolts, lock washers and hex nuts. Snug up. Do not tighten.
10. Install the other two 5/8" NC x 2" bolts in the center cross frame/main frame holes. Do not tighten.
11. Swing the rear cross frame into position against the left main frame rear attaching plate, adjust to install saddle clamp and the four 3/4" NC x 3" bolts, lock washers and hex nuts. Snug up. Do not tighten. Both saddle clamps must be loose enough to slide on the rear cross member for final adjustment.
12. Install the pivot connection frame on to the front cross member of the front main frame. Insure that the center of the pivot connection frame matches the center of the front main frame. Place clamp plates behind the front cross member and match up holes with pivot connection frame. Install eight 7/8" N.C. x 7 1/2" Grade 8 bolts with lock washers and hex nuts and tighten.
13. Install the pivot frame on to the bottom of the pivot connection frame. Line up holes and install the two pivot clevis pins and two 1/4" x 3" cotter pins.
14. Hoist the tongue into positions at the front of the machine. Line up the two holes at the rear of the tongue with the two holes on the pivot frame. Install the pivot pin clevis in the front hole. Secure it with a 1 1/2" fine thread castellated nut and 1/4" x 3" cotter pin. Also, install the tongue lock out pin with a 1/4" x 1-3/4" lynch pins in the rear hole.
15. Install loose linkage, hydraulic cylinder, lock-out bar and turnbuckle assembly.
 - a. Install lower loose link first. Place the wide end of the lower loose link into the pivot pin clevis. Insure that the second hole from the front is closer to the top edge. Place the narrow end of the lower loose link between the tongue clevis plate. Line up the front hole of the lower loose link with the hole in the

tongue clevis plates and install one 1" x 2 1/2" clevis pin and one 1/4" x 1 3/4" lynch pin.

- b. Install the upper loose link. The top end of the upper loose link has three holes and one notch. The notch should face the machine. The bottom end with one hole to be placed in between the center clevis plates of the pivot pin clevis. Position the holes of the lower and upper loose links to match the holes of the pivot pin clevis plates and install one 1" N.C. x 6" Grade 5 bolts and one 1" nylon lock nut.
 - c. Install 3 1/2" x 10" tie rod cylinder. Connect the rear end (with extend port) to the cylinder anchor in the center of the front cross member. Insure that the extend port at the rear end faces to one side and that the retract port at the front end faces down. Connect the front end to the upper loose link (second hole from the top). Use two 1" cylinder pins and four hitch pin clips.
 - d. Install cylinder lock out bar. The end with the ring should face the front. Connect the rear end to the front cross member lockout anchor which is located on the top of the main frame. Connect the front end to the top hole of the upper loose link. Use two 1" x 2 1/2" clevis pins. Install a 1/4" x 3" cotter pin to the rear clevis pin and a 1/4" x 1 3/4" lynch pin to the front clevis pin.
 - e. Install turnbuckle assembly. Connect one end to the upper loose link and the other end to the lower loose link. Use two 1" x 2 1/2" clevis pins and two 1/4" x 1 3/4" lynch pins. Adjust tongue to be parallel with the ground by adjusting the turnbuckle.
16. Install rear inside frame. Use four 5/8" NC x 2" bolts, lock washers and hex nuts. Snug up only to allow slight movement.
17. Install front cross brace. Use two 3/4" NC x 2" bolts, lock washers and hex nuts. Snug up only.
18. Install front cross frame between the front cross brace and main frame. Use one 3/4" NC x 2" bolt, lock washer and hex nut and two 5/8" NC x 2" bolts with lock washers and hex nuts. Snug up only.

19. Install right and left pull braces (the left one has two pins welded to it to mount the front turnbuckle when leveler is in field position) using four 3/4" NC x 2" bolts, lock washers and hex nuts. Attach between the front cross brace and the bucket cross brace. Snug up only.
20. Install front tie bars. Attach the right and left inside tie bars (with the factory edge facing up and away from the machine) between the pivot connection frame inside anchor plates and the front main frame ears. Use four 3/4" N.C. x 2" bolts with lock washers and hex nuts. Attach the right and left outside tie bars (with the factory edge facing up and in towards machine) between the pivot connection frame outside anchor plates and the cross frame. Use four 3/4" N.C. x 2" bolts with lock washers and hex nuts. Attach the tie bar across brace (with factory edge facing down and towards the rear of the machine) to the outside tie bars with two 3/4" N.C. x 2" bolts with lock washers and hex nuts.
21. Push the tire axle under the main frame. Align the tire axle so that when mounted to the rear of the bucket, the cylinder anchors are on the backside toward the rear cross frame. Now push the tire axle up until the legs slide into the gussets on the rear of the bucket. Line up the holes and insert a 1" NC x 3-1/2" bolt with zerks, through each hole. Put a locknut on each bolt and tighten.
22. Install two short cross rods (crossed) between the center cross frame and the rear inside frame. Use two 5/8" NC x 2" bolts, lock washers and hex nuts at center cross frame and two 5/8" NC x 2" bolts, lock washers and hex nuts at the rear inside frame end. Leave the rod assemblies loose.
23. Now install the two long cross rods (crossed) between the rear inside frame and the rear cross frame. Use two 5/8" NC x 2" bolts, lock washers and hex nuts at the rear cross frame end and two 5/8" NC x 2" bolts, lock washers and hex nuts at the rear inside frame end. Leave the rod assemblies loose.
24. Adjust the right and left main frame spacing on the rear cross frame. It should be centered by measuring from head tube to edge of main frame plate and sighting along the outside edge of both main frames to make sure they are not bowed in or out. Then tighten all eight saddle clamp bolts and nuts securely.
25. Tighten up all eight cross rod attaching bolts.
26. Tighten up all four cross rod turnbuckles sufficiently to square up the frames. Then install the cross rod U-

bolts.

27. Tighten all bolts in front cross frame, bucket cross brace and rear inside frame.
28. Install T-bar lift arms on bucket top rear section with cylinder attaching extension pointing toward the front of the machine and the short end (distance from end hole to cylinder attaching hole) mounted on the bucket. Use one 1" NC x 6" bolt with nylon lock nut.
29. Install lift link turnbuckle assembly onto the end of the center cross frame. Align the turnbuckle so that the locking handle is located at the top; now slide the tube over the stub. Install end plate and 1/2" NC x 1-1/2" bolt with lock washer. To attach the bottom end of the lift link assembly, line up the lift link clevis end with the T-bar link end hole. Adjust the turnbuckle by turning, clockwise or counterclockwise until the mating holes line up and the 1" NC x 3-1/2" bolt can be installed; then install 1" nylon lock nut. Make sure the grease fitting is facing out for ease of lubricating.
30. To install the other lift link, follow the same procedure as indicated in Step 27.
31. Install two 3-1/2" x 8" cylinders onto the tire axle. Use 1" x 4" cylinder pins. Position the shaft end clevis straddle of the cylinder attaching lug. Insert the cylinder pin and secure with hitch pin clips. Position the other clevis end straddle of the bucket attaching lug. Insert the cylinder pin and secure with hitch pin clips.
32. Install hydraulic piping and fittings from the front of the machine to the tire axle and install the 33" hoses into the upper port of the cylinders and the lower set of cross pipes. Use teflon tape for thread sealant on all pipe and hose joints. Support the piping with five double pipe clamps; one on the angle welded on the top front of the main frame, one on the front cross brace, one on each pipe hanger located on center cross frame base angle pointing toward the ground. Use five 5/16" NC x 2-1/2" bolts, lock washers and hex nuts.
33. Install one straight link lock between the T-bar and cylinder adjusting screw, which is mounted on the bucket hanger tube (one on each side of the machine) using two 1" NC x 3" bolts, lock washer and hex nuts mounted to the adjusting screw and two 1" NC x 3" bolts with nylon lock nuts mounted to the T-bar link.
34. Make a final check of the assembled landleveler. Cross rods should be tightened. The jam nut should be locked

up against the turnbuckle. The front turnbuckle must be adjusted correctly. Lock pins should be in place. Make sure all frame and cross member bolts are tight. Saddle clamp bolts must be tight and positioned correctly on the rear cross frame.

35. Optional bucket hydraulics with the transport hydraulics. Install pipes and fittings from the front of the machine to the center cross frame base angle; also the cross pipes. Use four double pipe clamps; one on the front main frame opposite the transport pipe hanger with 5/16" x 2-1/2" bolts, lock washers and hex nuts, two piggyback on top of the transport pipe clamps with 5/16" x 5" bolts, lock washers & hex nuts, and two on each pipe hanger located on the center cross frame opposite the transport cross lines with 5/16" x 2-1/2" bolts, lock washers and hex nuts.

TO TRANSPORT THE LANDLEVELER ON THE ROAD:

1. Move the bucket to its lowest position, then install the cylinder locking bars. The tire axle will be up and lock pins in place. Remove both lock pins from the tire axle. Lower the tire axle hydraulically until the lock pins can be reinserted into the same holes. This will lock the wheels into the transport position with the rear steel wheels off the ground.
2. Align the tongue with the frame center line, then insert the red tongue lockout pin located behind the pivot pin clevis. Insert the red lower loose link pin located on the tongue. Insert the red cylinder lockout bar pin located under the ring.
3. Adjust the front turnbuckle to hookup to the tractor drawbar, then readjust for the wheel/ground clearance desired.
4. Do not try to move the landleveler on the road on its steel wheels. Always use the transport wheels when moving on roadways.

TO LOWER LANDLEVELER FOR LAND LEVELING:

1. Lower the tire axle hydraulically enough to remove the locking pins. Raise the tire axle slowly until the front or rear wheels touch the ground. Adjust the front turnbuckle until the pins are free.

2. If the machine does not have a hydraulically actuated bucket, lift arm locks must be used on each side.
3. Remove the red tongue lockout pin located behind the pivot pin clevis. Remove the red lower loose link pin located on the tongue. Remove the red cylinder lockout bar pin located under the ring. Place them in their respective pin holders.
4. The bucket leveling and depth adjustments are made by adjusting the lift screws located on each side of the landleveler.
5. Check the rear wheels for travel alignment:
 - a. Loosen both stabilizer bearing cap screws to assure that the bearing or roller is free to move in the slot.
 - b. Stretch a string from the outside of one wheel rim to the outside of the opposite wheel rim approximately 14" off of and parallel to the ground.
 - c. Adjust each wheel so that the string touches the full surface of each wheel rim with no bend in the string. (Visually check from outside of one wheel to the outside of the other)
 - d. Retighten the bearing or roller cap screws in the stabilizer.
 - e. Remove the string and now the landleveler is ready to use.
6. Operating the machine under adverse conditions, such as extremely rough ground, rocks or stumps, may cause the hitch end bolt to break. If this occurs, do not replace the factory installed bolt with a case hardened bolt. It is intended to be a safety shear pin.
7. Hydraulic Cylinder option. Adjust cylinder adjusting screw, located on the piston end of the bucket cylinder, so that the pivot point (A) is located 1/8" forward of a direct line between the upper turnbuckle; attach point (B) and the lower attach point (C) on each side of the machine. (See Drawing on the following page)
8. Adjust the bucket lift turnbuckle to "Level", set blade and working height of the bucket.

9. Recheck adjustment No. 7 above, to make sure pivot point is within tolerance (0" to 1/8"). If necessary, readjust No. 7 and No. 8 above.

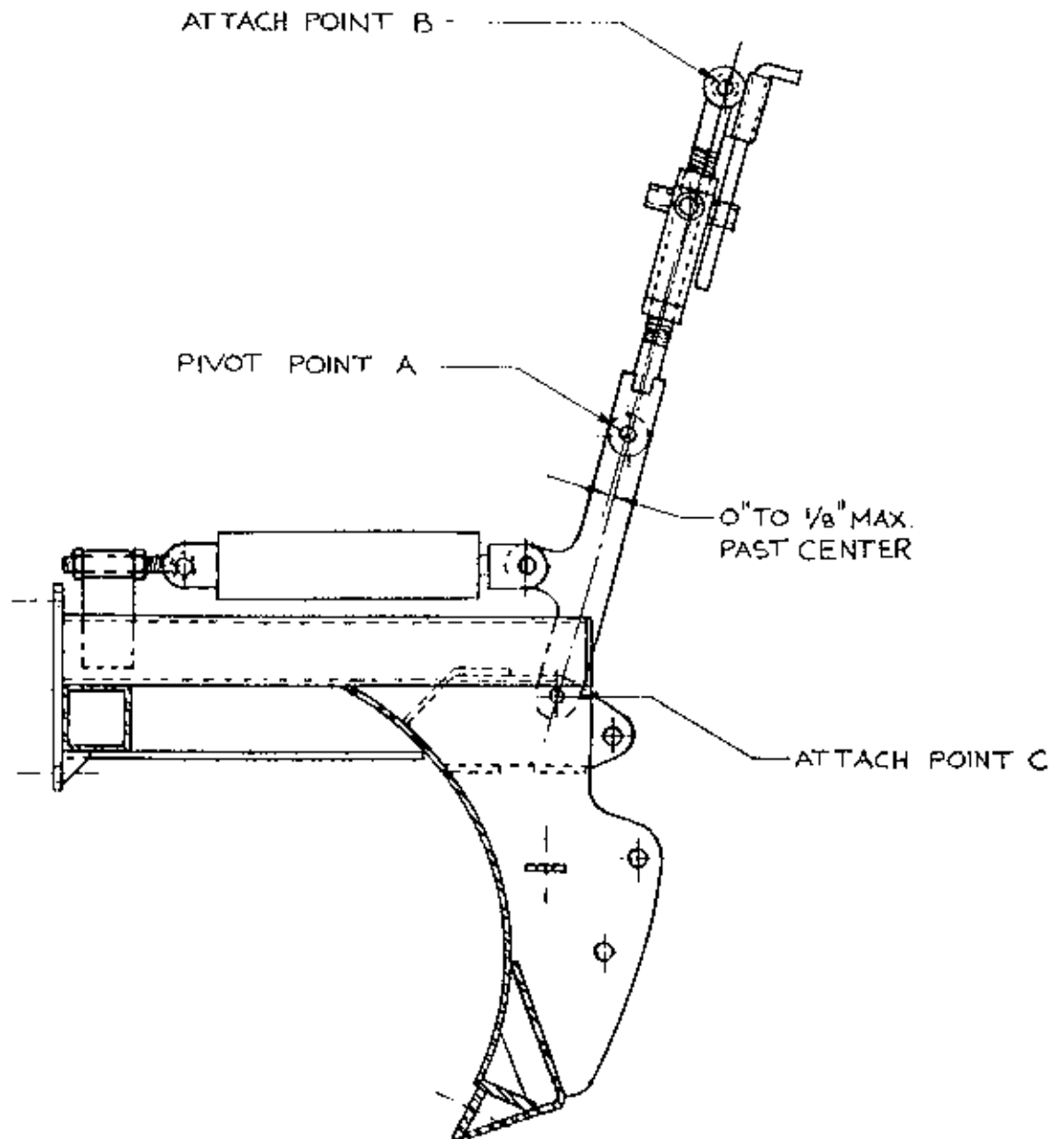
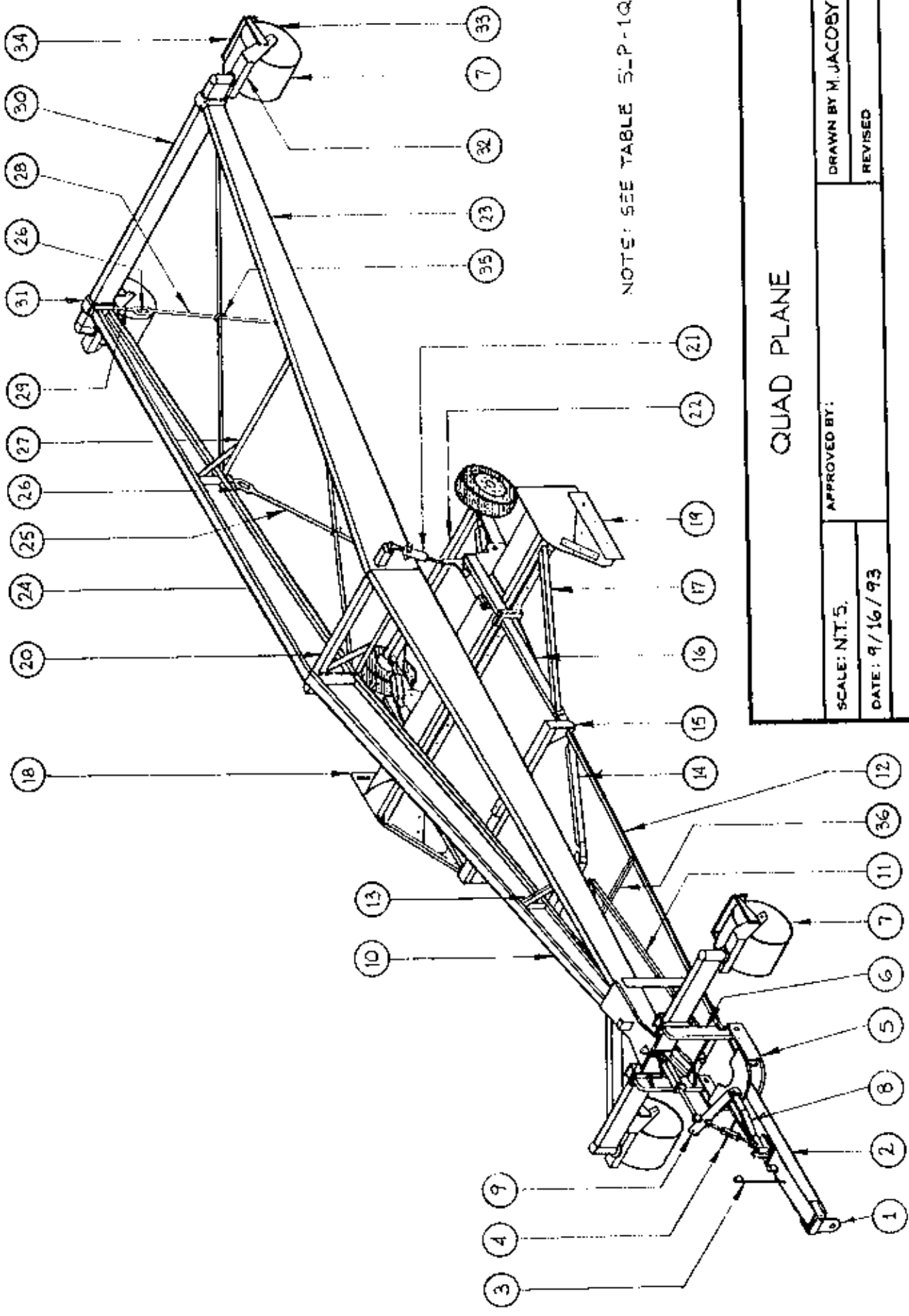

TABLE SLP-1 Q

<u>ITEM NO.</u>	<u>PART NO.</u>	<u>DESCRIPTION</u>	<u>QUANTITY</u>	<u>NOTES</u>
1	SLP-Q2	TONGUE HITCH	1	
2	SLP-R4	TONGUE	1	
3	SLP-Q5	HYDRAULIC LINE SUPPORT	1	
4	SLP-R7-3	FRONT TURNBUCKLE ASSEMBLY	1	
5	SLP-R3	PIVOT FRAME	1	
6	SLP-R2	PIVOT CONNECTION FRAME	1	
7	SLP-D	STEEL WHEELS	4	
8	SLP-R7-2	LOWER LOOSE LINK	1	
9	SLP-R7-1	UPPER LOOSE LINK	1	
10	SLP-R1	TOP FRAME, FRONT	1	
11	SLP-R2-11	INSIDE TIE BAR	2	
12	SLP-R2-12	OUTSIDE TIE BAR	2	
13	SLP-G	FRONT CROSS FRAME	1	
14	SLP-J2	PULL BRACE - (1) R.H. (1) L.H.	2	
15	SLP-J1	CROSS BRACE - T.F. TO BUCKET	1	
16	SLP-K	BUCKET PULL ARM	2	
17	SLP-K-7	PULL ARM TIE BAR (1)L.H. (1) R.H.	2	Specify bucket size
18	SLP-L1	BUCKET (14', 16', 18', 20' sizes)	1	
19	SLP-L2	BUCKET SIDES (1)L.H. (1)R.H.	2	
18 & 19	SLP-L	BUCKET - COMPLETE (14' to 20')	1	
20	SLP-F	CENTER CROSS FRAME	1	
21	SLP-M	BUCKET LINKAGE	2	
22	SLP-H	TIRE AXLE	1	
23	SLP-A2 L.H.	TOP FRAME, REAR - L.H.	1	
24	SLP-A2 R.H.	TOP FRAME, REAR - R.H.	1	
25	SLP-A4	FRONT ROD - 114"	2	
26	SLP-ABO-1	3/4" x 6" TURNBUCKLE	4	
27	SLP-E	REAR INSIDE FRAME	1	
28	SLP-A5	REAR ROD - 126"	2	
29	SLP-A3	L.H. THRD. STUB END	4	
30	SLP-C1	REAR CROSS FRAME	1	14' - 140'
31	SLP-C2	REAR FRAME SADDLE CLAMP	2	16', 18', 20'-157½'
32	SLP-B1	STEEL WHEEL FRAMES	4	
33	SLP-B2	SCRAPER BLADE ARM (4)R.H. (4)L.H.	8	
34	SLP-B2-3	SCRAPER BLADE - REAR	4	
35	SLP-ABO-2	1½" U-BOLTS	2	
36	SLP-R2-13	TIE BAR CROSS BRACE	1	



NOTE: SEE TABLE SLP-1Q

QUAD PLANE

APPROVED BY:		DRAWN BY M. JACOBY	
SCALE: N.T.S.		REVISED	
DATE: 9/16/93			
3160 E. CALIFORNIA AVE. FRESNO, CA 93714			
COMPLETE ASSEMBLY DRAWING		DRAWING NUMBER SLP-R	

TABLE SLP-2

<u>ITEM NO.</u>	<u>PART NO.</u>	<u>DESCRIPTION</u>	<u>QUANTITY</u>
1.	SLP-14-L	BUCKET 14'	1
	SLP-16-L	BUCKET 16'	1
	SLP-18-L	BUCKET 18'	1
2.	SLP-K	BUCKET PULL ARM	2
3.	SLP-K-7R	PULL ARM TIE BAR (R.H.)	1
4.	SLP-K-7L	PULL ARM TIE BAR (L.H.)	1
5.	SLP-J1	CROSS BRACE (Top Frame to Bucket)	1
6.	SLP-L2R	BUCKET SIDE (R.H.)	1
7.	SLP-L2L	BUCKET SIDE (L.H.)	1
8.	SLP-L2-4	BUCKET SIDE ADJ. BLADE	2
9.	SLP-14-L1-23	3/8 X 4 SINGLE BLADE 14'	1
	SLP-16-L1-23	3/8 X 4 SINGLE BLADE 16'	1
	SLP-18-L1-23	3/8 X 4 SINGLE BLADE 18'	1
10.	SLP-14-L1-24	1/2 X 6 DOUBLE BLADE 14'	1
	SLP-16-L1-24	1/2 X 6 DOUBLE BLADE 16'	1
	SLP-18-L1-24	1/2 X 6 DOUBLE BLADE 18'	1

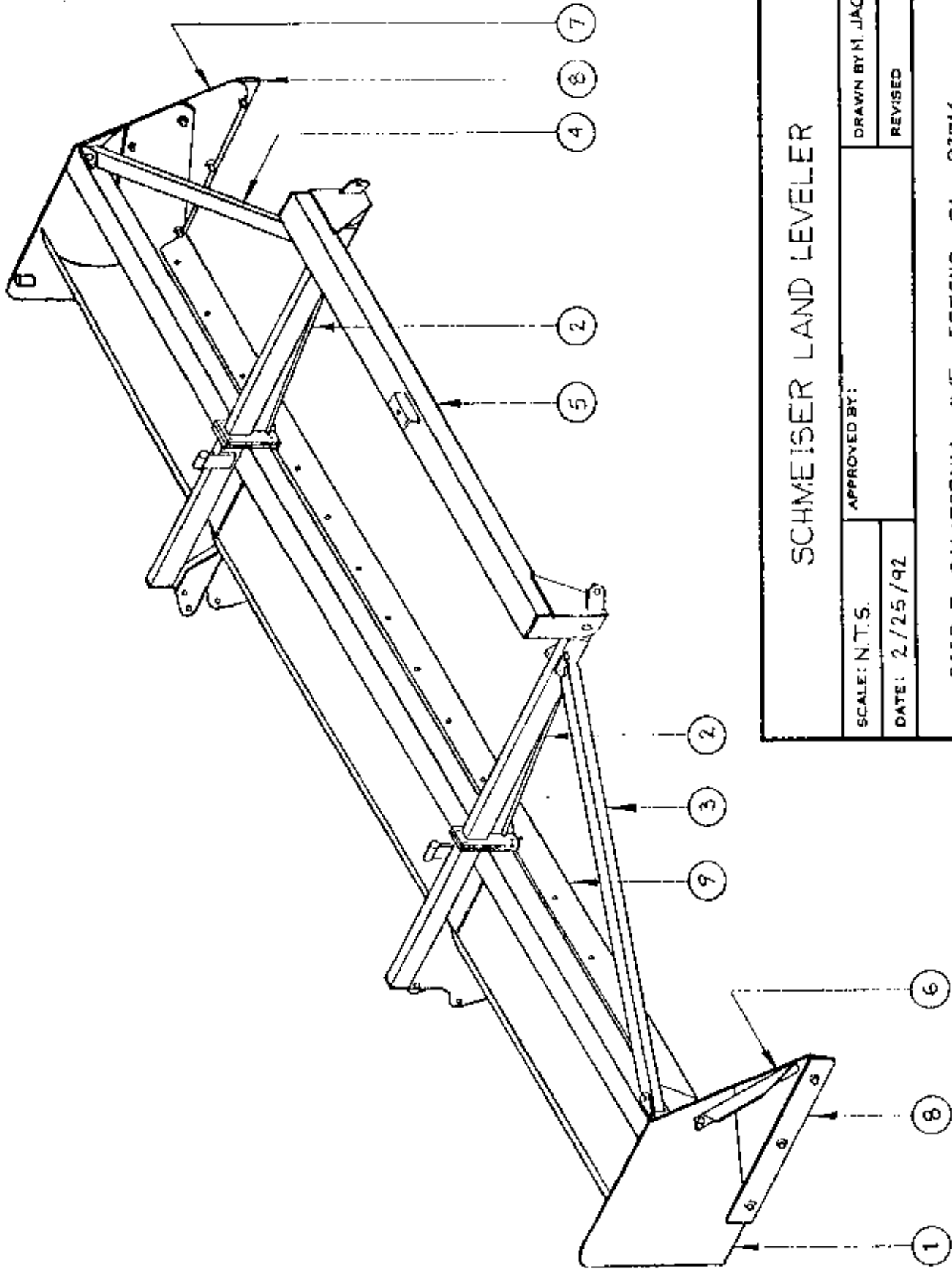

SCHMEISER LAND LEVELER

APPROVED BY:		DRAWN BY M. JACOBY	
SCALE: N.T.S.		REVISED	
DATE: 2/25/92			
3160 E. CALIFORNIA AVE., FRESNO CA 93714			
BUCKET ASSEMBLY DNG.		DRAWING NUMBER	
		SLP - 2	

NOTE: SEE TABLE SLP - 2

TABLE SLP-3

VARIED QTY'S & LENGTHS.

ITEM NO.	PART NO.	DESCRIPTION	QTY'S TYP. ALL MACHINES	14' MACHINE	16' MACHINE	18' MACHINE
1.	SLP-14-L1	BUCKET 14'	1	168"		
	SLP-16-L1	BUCKET 16'	1		192"	216"
	SLP-18-L1	BUCKET 18'	1			
2.	SLP-14-L1-23	3/8 X 4 SINGLE BLADE	1	167-1/2"	191-1/2"	215-1/2"
	SLP-16-L1-23	3/8 X 4 SINGLE BLADE	1			
	SLP-18-L1-23	3/8 X 4 SINGLE BLADE	1			
	SLP-14-L1-24	1/2 X 6 DOUBLE BLADE	1	167-1/2"	191-1/2"	
	SLP-16-L1-24	1/2 X 6 DOUBLE BLADE	1			
	SLP-18-L1-24	1/2 X 6 DOUBLE BLADE	1			
3.	SLP-K-7R	PULL ARM TIE BAR(R.H.)	1	52-13/16"	61-13/16"	72-1/16"
4.	SLP-K-7L	PULL ARM TIE BAR(L.H.)	1	52-13/16"	61-13/16"	72-1/16"
5.	SLP-J2R	PULL BRACE (R.H.)	1			
6.	SLP-J2L	PULL BRACE (L.H.)	1			
7.	SLP-J1	CROSS BRACE	1			
8.	SLP-K-R	BUCKET PULL ARM (R.H.)	1			
	SLP-K-L	BUCKET PULL ARM (L.H.)	1			
9.	SLP-L2R	BUCKET SIDE (R.H.)	1			
10.	SLP-L2L	BUCKET SIDE (L.H.)	1			
11.	SLP-L2-4	BUCKET SIDE ADJ. BLADE	2	(15)	(17)	(19)
12.	---	5/8" x 1-3/4" FLOW BOLT	-			
13.	---	5/8" x 2" Gr. 5 z/p BOLTS	16			
14.	---	3/4" x 2" Gr. 5 z/p BOLTS	12			
15.	---	1" x 4-1/2" Gr. 5 z/p BOLTS	2	(15)	(17)	(19)
16.	---	5/8" FLAT WASHERS	-			
17.	---	5/8" FLAT WASHERS	6	(15)	(17)	(19)
18.	---	5/8" LOCK WASHERS	-			
19.	---	5/8" LOCK WASHERS	16	(15)	(17)	(19)
20.	---	3/4" LOCK WASHERS	12			
21.	---	5/8" HEX NUTS	-	(15)	(17)	(19)
22.	---	5/8" HEX NUTS	16			
23.	---	3/4" HEX NUTS	12			
24.	---	1" LOCK NUTS	2			
25.	---	1" x 2-1/2" CLEVIS PIN	2			
26.	---	1/4" x 1-3/4" LYNCH PIN	2			

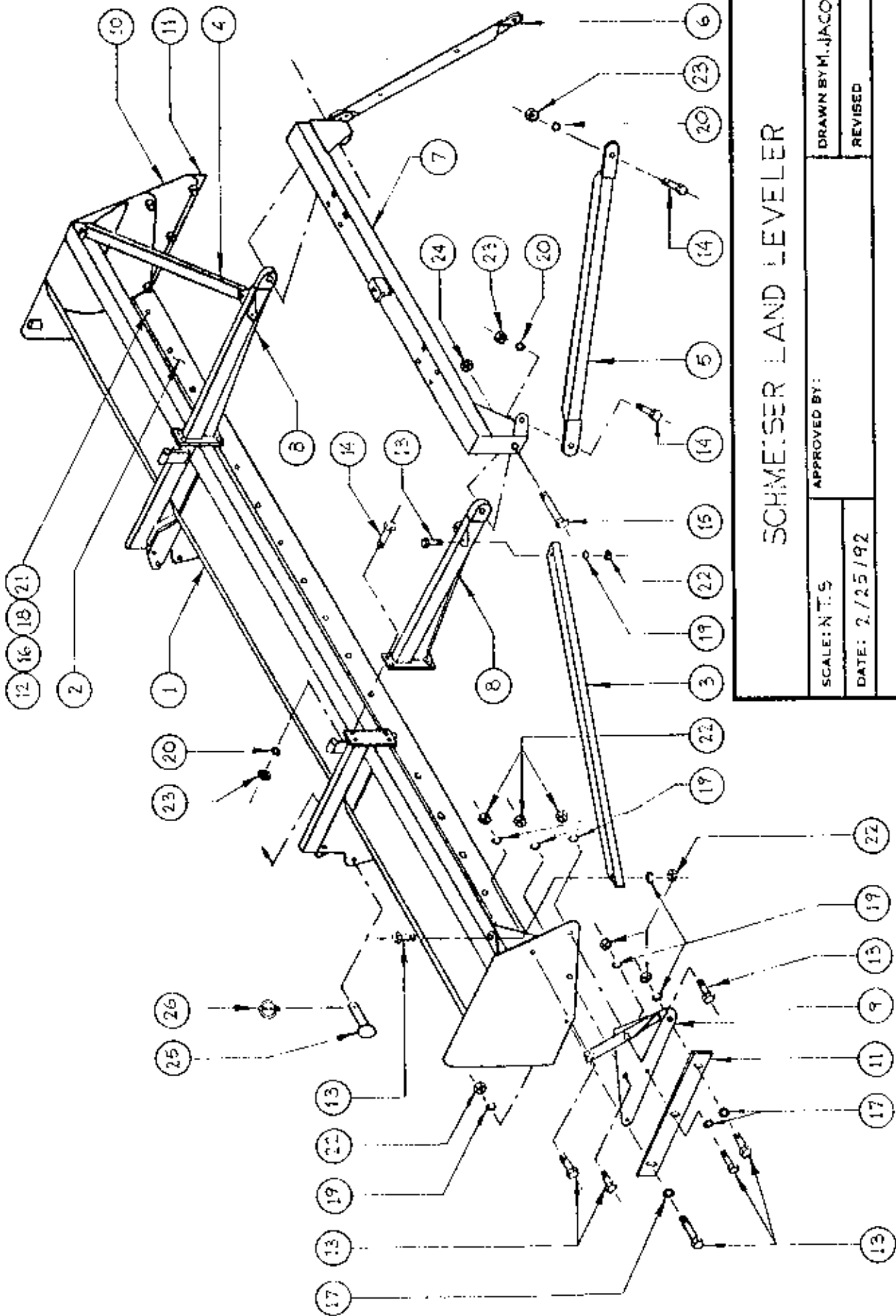

SCHMEISSER LAND LEVELER

APPROVED BY:		DRAWN BY M. JACOBY	
SCALE: N.T.S.		REVISED	
DATE: 2/25/92			
3160 E. CALIFORNIA AVE., FRESNO CA 95714			
BUCKET BOLT-UP ASSEMBLY DNG.		DRAWING NUMBER	
		SLP-3	

NOTE: SEE TABLE SLP-3

TABLE SLP-4

<u>ITEM No.</u>	<u>PART No.</u>	<u>DESCRIPTION</u>	<u>QTY</u>
1	SLP-M4	BUCKET LINKAGE ADJ. ROD	2
2	SLP-M-6	STRAIGHT LINK	2
3	SLP-M-5	T-BAR LINK	2
4	SLP-M2	LOWER TURNBUCKLE STUB	2
5	SLP-M3	TURNBUCKLE CRANK	2
6	SLP-M1	UPPER TURNBUCKLE STUB	2
7	SLP-M1-4	TURNBUCKLE END PLATE	2
8	SLP-M1-5	TURNBUCKLE CRANK ROD	2
9	- - -	1" x 3" Gr.5 z/p BOLT	4
10	- - -	1" x 6" Gr.5 z/p BOLT w/ ZERK HOLE	2
11	- - -	1" x 3½" Gr.5 z/p BOLT w/ ZERK HOLE	2
12	- - -	½" x 1½" Gr.5 z/p BOLT	2
13	- - -	THREADED GREASE ZERKS	2
14	- - -	PRESSED-IN GREASE ZERKS	6
15	- - -	1" LOCK WASHER	2
16	- - -	½" LOCK WASHER	2
17	- - -	1" z/p HEX NUT	2
18	- - -	1" JAM NUT	4
19	- - -	1" NYLON LOCK NUT	6

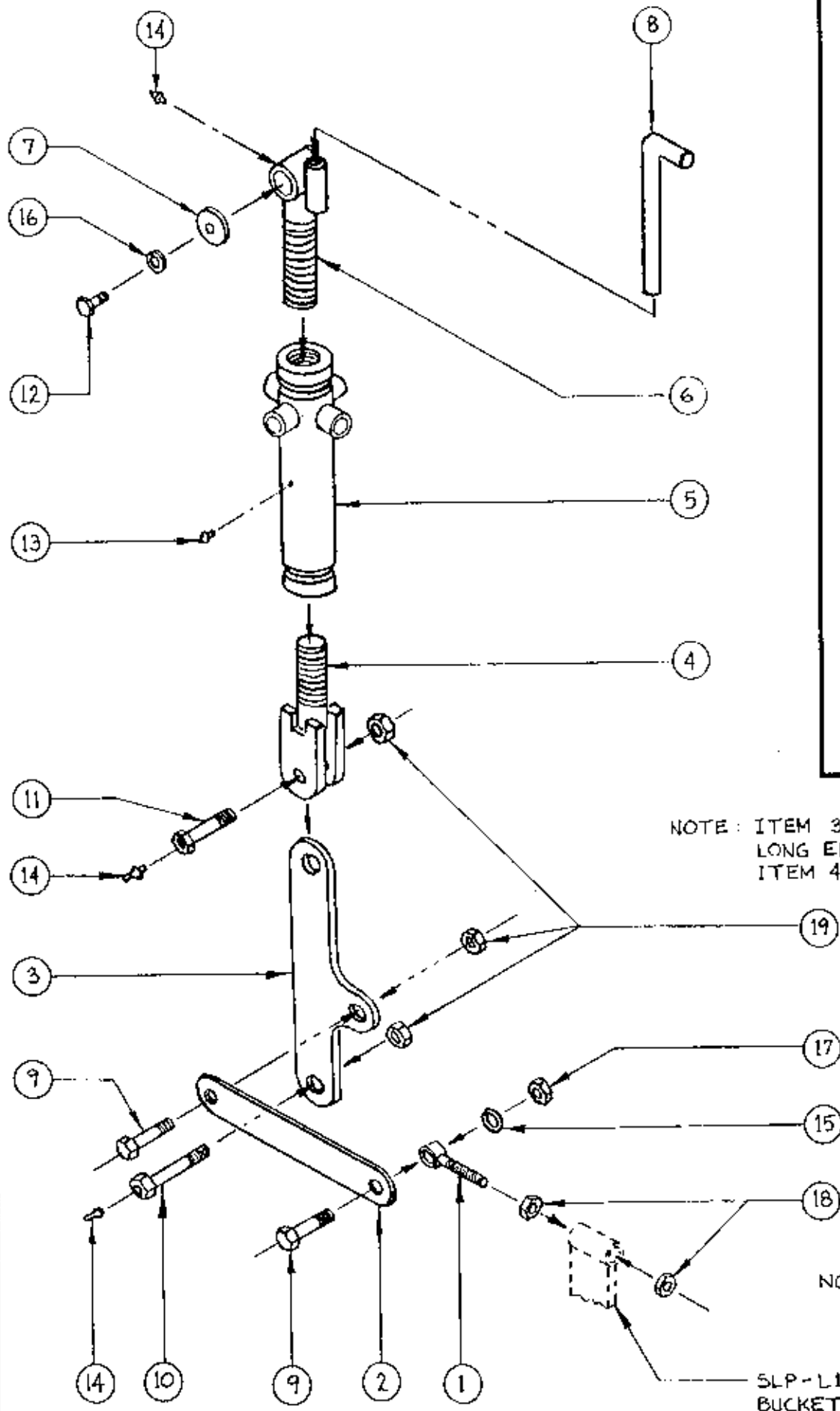

SCHMEISER LAND LEVELER

DRAWN BY M. JACOBY
 REVISED
 APPROVED BY:
 SCALE: N.T.S.
 DATE: 2/26/92

3160 E CALIFORNIA AVE., FRESNO CA 93714

DRAWING NUMBER
 SLP - 4
 BUCKET LINKAGE ASSEMBLY DWG.

NOTE: ITEM 3 INSTALLED WITH LONG END ATTACHED TO ITEM 4

NOTE: SEE TABLE SLP-4

SLP-L1 (L1-13, L1-14)
BUCKET REF.

8 1/2 X 11 PRINTED ON NO. 10000 CLEARPRINT

TABLE SLP-5 Q

<u>ITEM NO.</u>	<u>PART NO.</u>	<u>DESCRIPTION</u>	<u>QTY</u>
1	SLP-Q2	TONGUE HITCH	1
2	SLP-Q6	TONGUE HITCH CLEVIS PIN	1
3	SLP-Q5	HYDRAULIC LINE SUPPORT	1
4	SLP-R4	TONGUE	1
5	SLP-R3	PIVOT FRAME	1
6	SLP-R2	PIVOT CONNECTION FRAME	1
7	SLP-R7-2	LOWER LOOSE LINK	1
8	SLP-R7-1	UPPER LOOSE LINK	1
9	SLP-R7-4	CYLINDER LOCKOUT BAR	1
10	SLP-R5	PIVOT PIN CLEVIS	1
11	SLP-R6	TONGUE LOCKOUT PIN	1
12	SLP-R2-1	CLAMP PLATES	1
13	SLP-R1	TOP FRAME	1
14	SLP-R8	PIVOT CLEVIS PIN	2
15	- - -	1" x 2-1/2" CLEVIS PINS	3
16	- - -	7/8" x 7-1/2" Gr. 8 z/p BOLT	8
17	- - -	7/8" LOCK WASHERS	8
18	- - -	7/8" HEX NUTS	8
19	- - -	1-1/2" FINE THRD. CASTELL. NUT	1
20	- - -	3/4" LOCK WASHER	1
21	- - -	3/4" HEX NUT	1
22	- - -	1" x 6" Gr. 5 z/p BOLT	1
23	- - -	1" NYLON LOCK NUT	1
24	SLP-RHC-3 1/2 x 10	TIE ROD 3-1/2" x 10"	1
25	SLP-RBO-1	1" HYD CYLINDER PINS	2
26	SLP-RBO-2	HITCH PIN CLIPS	4
27	SLP-RBO-J	10", 5000 # JACK STAND	1
28	- - -	1/4" x 3" COTTER PIN	5
29	- - -	1/4" x 1-3/4" lynch pins	3

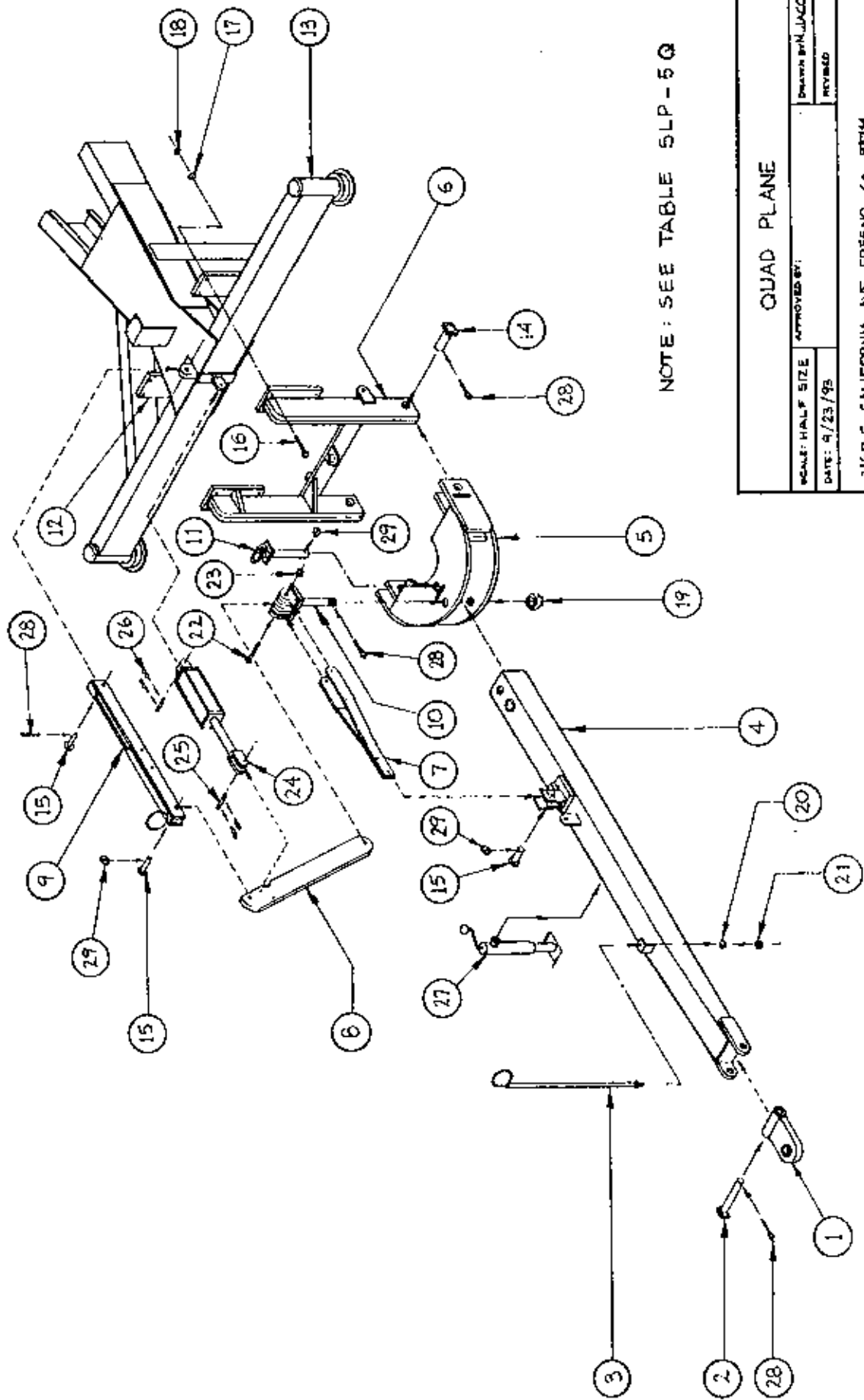

NOTE: SEE TABLE SLP-5Q

QUAD PLANE		APPROVED BY:	DESIGNED BY: J. JACOBY
SCALE: HALF SIZE	DATE: 9/23/95	REVISED	
3160 E. CALIFORNIA AVE. FRESNO, CA. 93714		DRAWING NUMBER: SLP-5Q	
TONGUE ASSEMBLY DIAG.			

TABLE SLP-7 Q

<u>ITEM No.</u>	<u>PART No.</u>	<u>DESCRIPTION</u>	<u>QTY.</u>
1	SLP-Q4B0-1	TURNBUCKLE BODY	1
2	SLP-R7-3R	R.H. THREADED ROD	1
3	SLP-R7-3A	L.H. THREADED ROD	1
4	- - -	1" x 2-1/2" CLEVIS PIN	2
5	- - -	1/4" x 1-3/4" LYNCH PIN	2

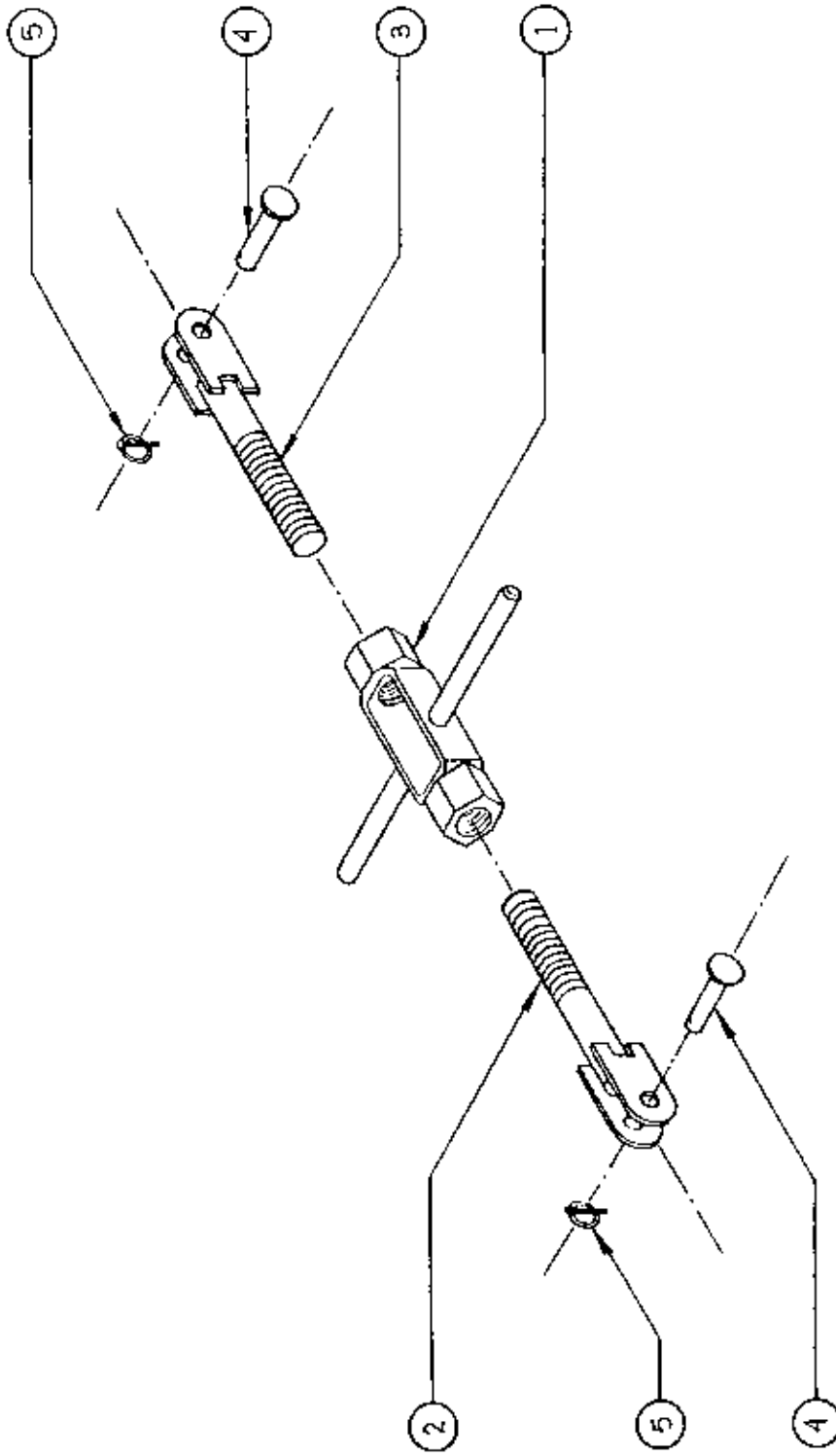

NOTE: SEE TABLE SLP-7Q

SCHMEISER LAND LEVELER

SCALE: N.T.S.	APPROVED BY:	DRAWN BY M. JACOBY
DATE: 3/25/92		REVISED
3160 E. CALIFORNIA AVE., FRESNO CA 93714		
FRONT TURNBUCKLE ASSEMBLY		DRAWING NUMBER
		SLP-7Q

TABLE SLP-9

<u>ITEM NO.</u>	<u>PART NO.</u>	<u>DESCRIPTION</u>	<u>QTY</u> (per machine)
1	SLP-B1	STEEL WHEEL FRAME	4
2	SLP-D	STEEL WHEELS	4
3	SLP-B2	SCRAPER BLADE ARM (4 L.H., 4 R.H.)	8
4	SLP-B2-3	SCRAPER BLADE	4
5	SLP-B3	LOCKING ARM	4
6	SLP-B3-4	LOCKING ARM BEARING BUSHING	4
7	SLP-A6	REAR FRAME BEARING HOUSING	4
8	SLP-A6-3	BEARING SHAFT CAP	4
9	- - -	PUSH-IN GREASE ZERK	4
10	SLP-A6BO- 4	HOUSING BUSHING	12
11	SLP-A6BO- 3	THRUST BEARING	4
12	SLP-A6BO- 1	OIL SEAL	4
13	SLP-B3BO-1	LOCKING ARM BEARING	4
14	SLP-BBO-S	LOCKING ARM SPRING	4
15	SLP-DBO-1	1-11/16" FLANGE BEARINGS	8
16	SLP-A6BO-5	HOUSING DUST CAP	4
17	- - -	1/2" x 1" Gr. 5 z/p BOLTS	4
18	- - -	1/2" x 1-1/2" Gr. 5 z/p BOLTS	8
19	- - -	1/2" x 2" Gr. 5 z/p BOLTS	16
20	- - -	1/2" x 2-1/4" Gr. 5 z/p BOLTS	36
21	- - -	1/2" FLAT WASHERS	20
22	- - -	7/8" LOCKNUT	4
23	- - -	1/2" LOCK WASHERS	60
24	- - -	1/2" HEX NUTS	56
25	- - -	1/2" NYLON LOCK NUT	4
26	- - -	THREADED GREASE ZERKS	4

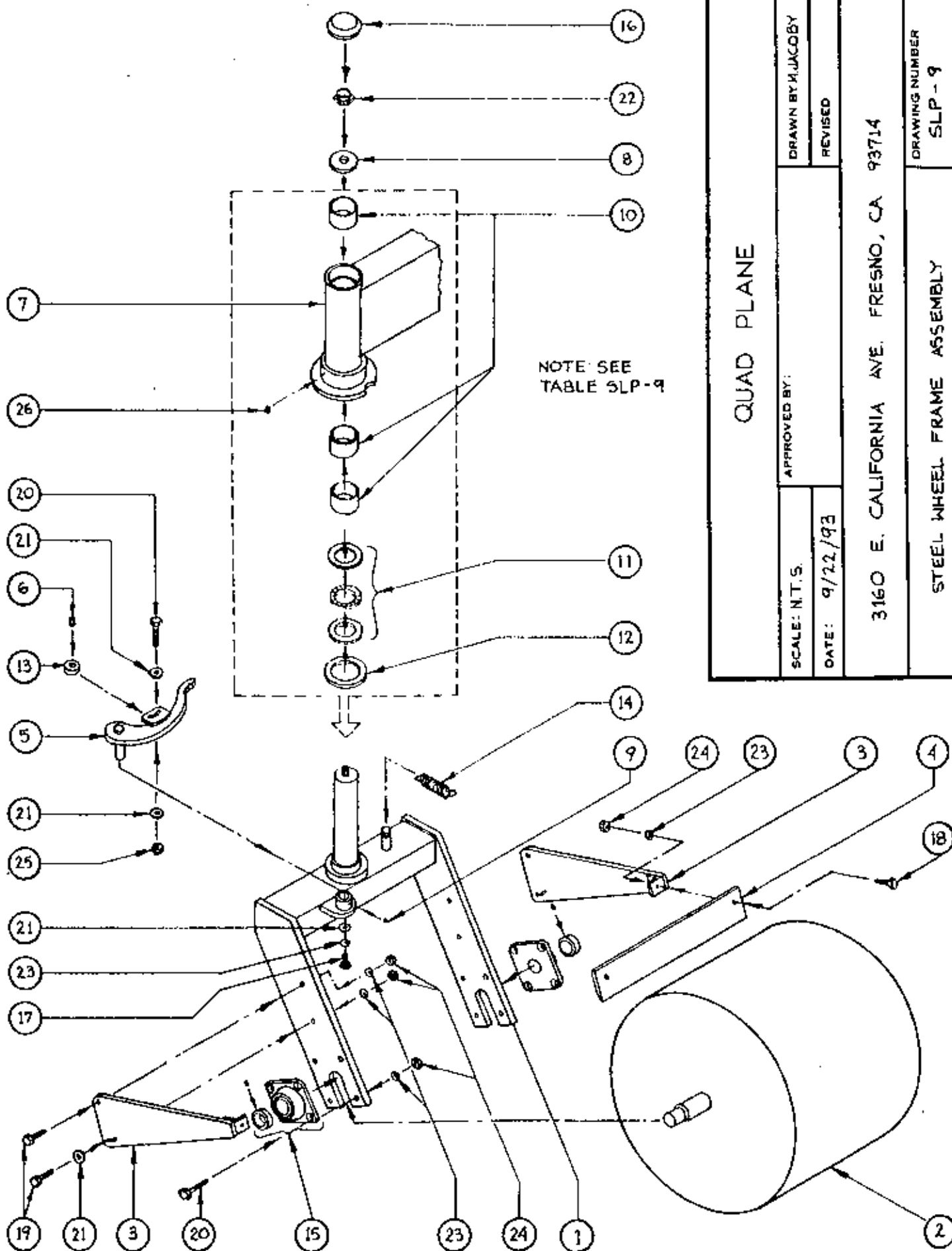

NOTE: SEE
TABLE SLP-9

QUAD PLANE

DRAWN BY H. JACOBY		3160 E. CALIFORNIA AVE. FRESNO, CA 93714	DRAWING NUMBER SLP - 9
REVISED			
SCALE: N.T.S.	APPROVED BY:		
DATE: 9/22/93			

TABLE SLP-10

<u>ITEM No.</u>	<u>PART No.</u>	<u>DESCRIPTION</u>	<u>QTY</u>
1	SLP-HBO-1	OIL SEAL	2
2	SLP-HBO-2	INNER BEARING CONE	2
3	SLP-HBO-3	INNER BEARING CUP	2
4	SLP-HBO-4	HUB, 8-HOLE	2
5	SLP-HBO-5	OUTER BEARING CUP	2
6	SLP-HBO-6	OUTER BEARING CONE	2
7	SLP-HBO-7	DUST CAP	2
8	SLP-HBO-8	10 x 16 WHEEL (8 on 8)	2
9	SLP-HBO-9	12 x 16 TIRE	2
10	SLP-HBO-10	TUBE	2
11	SLP-HBO-11	LUG BOLTS (8 per tire)	16
12	SLP-HBO-12	CASTLE NUT	2
13	SLP-HBO-13	FLAT WASHER	2
14	SLP-H	TIRE AXLE	2
15	- - -	1" x 3-1/2" Gr.5 z/p BOLTS	2
16	- - -	1" NYLON LOCKNUTS	2
17	- - -	PRESSED-IN GREASE ZERK	2
18	- - -	1/4" x 1-1/2" COTTER PIN	2

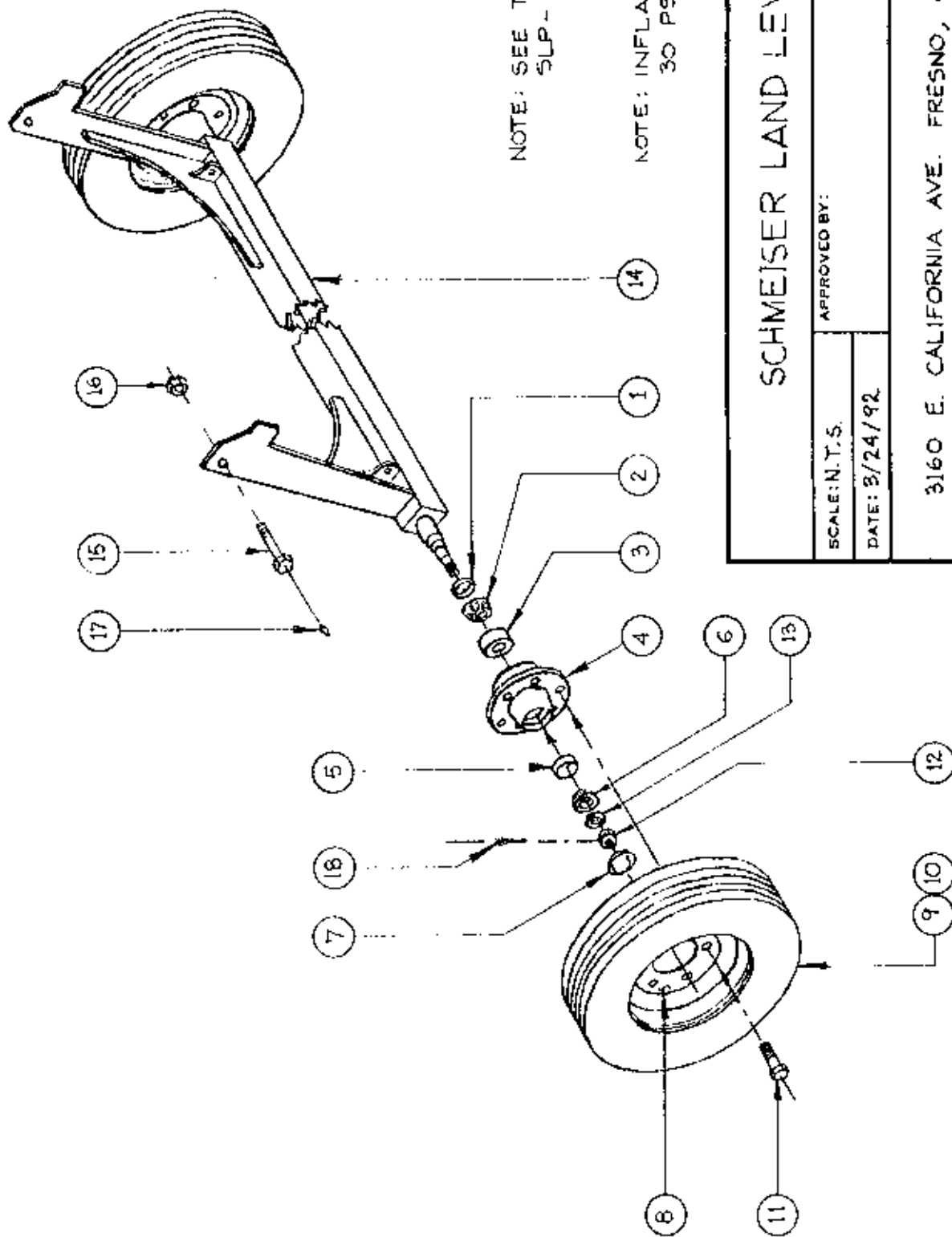

NOTE: SEE TABLE
SLP-10

NOTE: INFLATE TIRES TO
30 PSI

SCHMEISER LAND LEVELER

APPROVED BY:		DRAWN BY R S L JR.
SCALE: N.T.S.		REVISED
DATE: 3/24/92		
3160 E. CALIFORNIA AVE. FRESNO, CA 93714		
TIRE AXLE ASSEMBLY		DRAWING NUMBER
		SLP-10

TABLE SLP-11 Q

<u>ITEM No.</u>	<u>PART No.</u>	<u>DESCRIPTION</u>	<u>QTY</u>
1	SLP-A10B0-1	1/2" PIPE PLUGS	2
2	SLP-R9B0-1	1/2" NIPPLES	2
3	SLP-A10B0-H.C.	HOSE CLAMPS	4
4	SLP-R9-1	1/2" x 204" PIPE	2
5	SLP-A10B0-3	1/2" HYD. FLOW CONTROL VALVE	1
6	SLP-A10B0-4	1/2" PIPE TEE	1
7	SLP-A10-4	1/2" x 36" PIPE	4
8	SLP-A10B0-5	1/2" x 90 ELBOW	4
9	SLP-A10B0-H.L.33	HYD. HOSE 1/2" x 33"	2
10	SLP-A10B0-H.L.41	HYD. HOSE 1/2" x 41"	2
11	SLP-A10B0-H.C.3 1/2 x 8	HYD. CYLINDER 3 1/2" x 8"	2
12	SLP-A10B0-6	1" HYD. CYL. PINS	4
13	SLP-A10B0-7	HITCH PIN CLIPS	8
14	- - -	5/16" x 2 1/2" Gr.5 z/p BOLTS	5
15	- - -	5/16" LOCK WASHERS	5
16	- - -	5/16" HEX NUTS	5

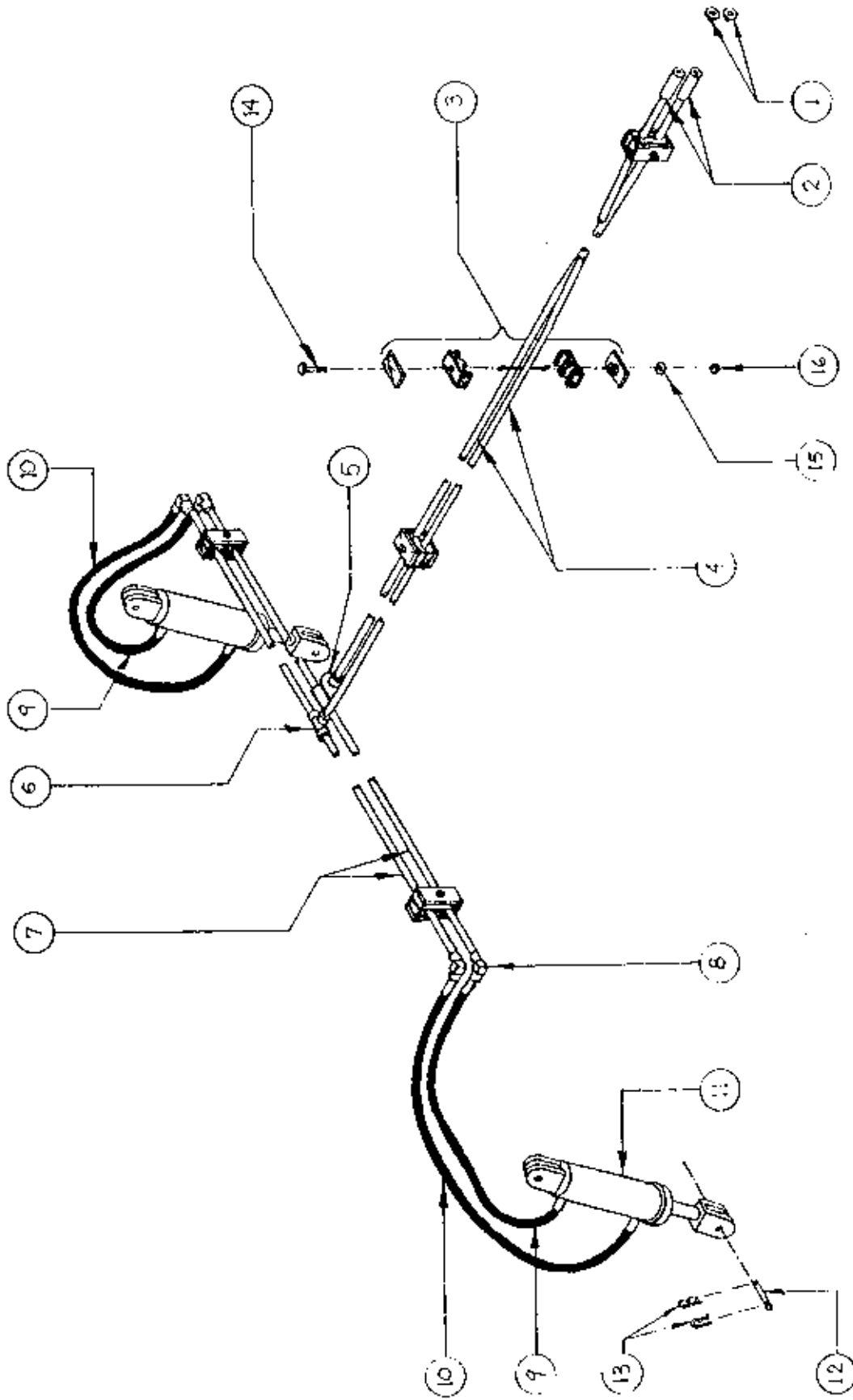

SCHMEISER LAND LEVELER

SCALE: N.T.S.	APPROVED BY:	DRAWN BY M. JACOBY
DATE: 4/1/92		REVISED

3160 E. CALIFORNIA AVE. FRESNO, CA 93714

HYDRAULIC SYSTEM ASSEMBLY

DRAWING NUMBER
SLP-11Q

NOTE: SEE TABLE SLP-11Q

TABLE SLP-12 Q

<u>ITEM No.</u>	<u>PART No.</u>	<u>DESCRIPTION</u>	<u>QTY</u>
1	SLP-A10B0-1	1/2" PIPE PLUGS	2
2	SLP-R9B0-1	1/2" NIPPLES	2
3	SLP-A10B0-H.C.	HOSE CLAMPS	4
4	SLP-R9-1	1/2" x 204" PIPE	2
5	SLP-A10B0-3	1/2" HYD. FLOW CONTROL VALVE	1
6	SLP-A10B0-4	1/2" PIPE TEE	1
7	SLP-A10-4	1/2" x 36" PIPE	4
8	SLP-A10B0-5	1/2" x 90 ELBOW	4
9	SLP-A10B0-H.L. 28	HYD. HOSE 1/2" x 28"	2
10	SLP-A10B0-H.L. 36	HYD. HOSE 1/2" x 36"	2
11	SLP-A10-H.C. 3x8	TIE ROD CYLINDER 3" x 8"	2
12	SLP-A10B0-8	1" HYD. CYL. PINS	4
13	SLP-A10B0-9	HITCH PIN CLIPS	8
14	- - -	5/16" x 2 1/2" Gr. 5 z/p BOLTS	5
15	- - -	5/16" LOCK WASHERS	5
16	- - -	5/16" HEX BOLTS	5

NOTE: SEE TABLE SLP-12 Q

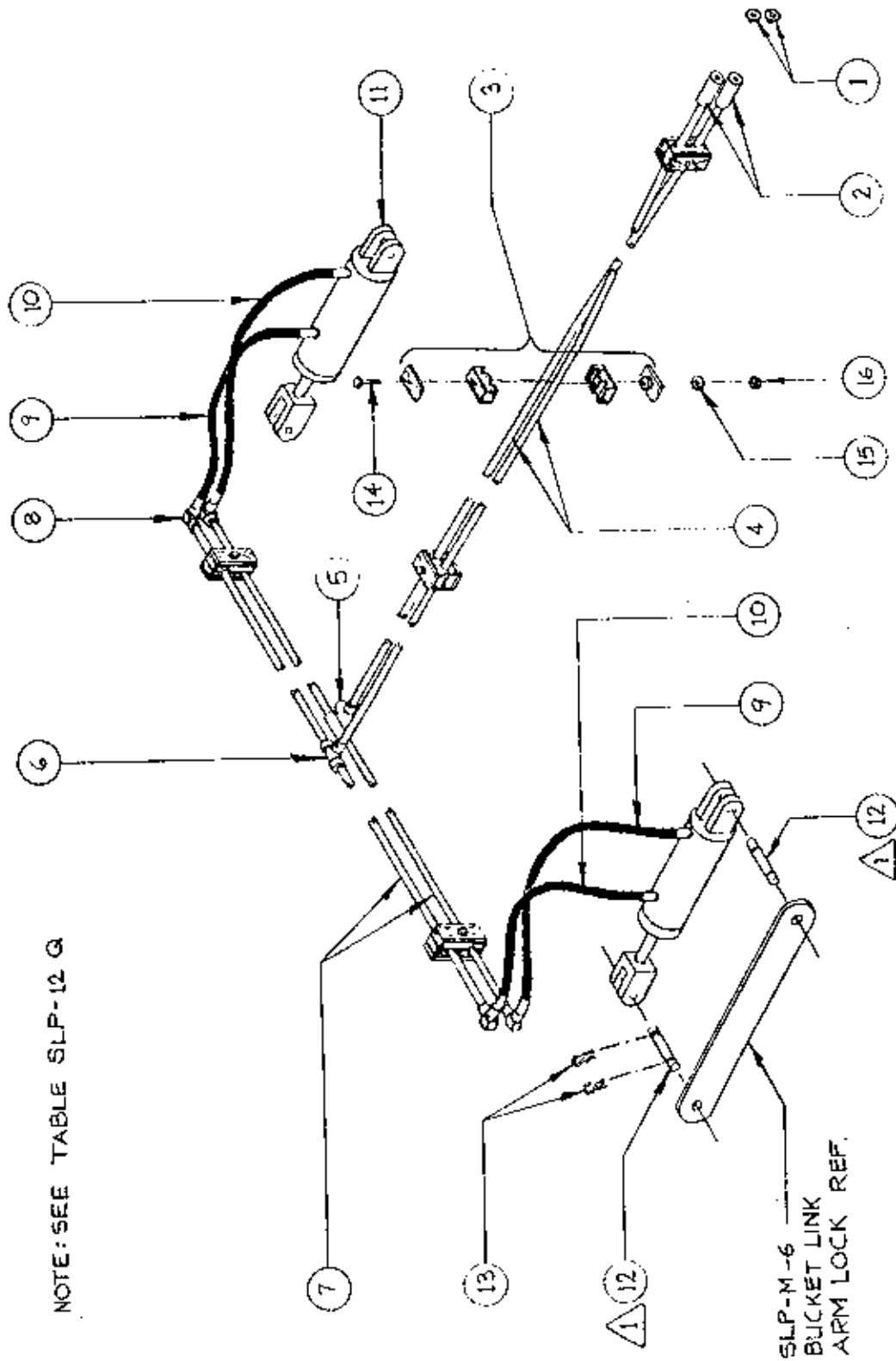

SLP-M-6
BUCKET LINK
ARM LOCK REF.

⚠ REPLACES 1" N.C. x 3" BOLT W/
NYLON LOCK NUT

SCHMEISER LAND LEVELER

SCALE: N.T.S.	APPROVED BY:	DRAWN BY H. JACOBY
DATE: 4/3/92		REVISED

3160 E. CALIFORNIA AVE. FRESNO, CA 93714

HYDRAULIC BUCKET LIFT SYSTEM ASSEMBLY	DRAWING NUMBER SLP-12 Q
---------------------------------------	----------------------------

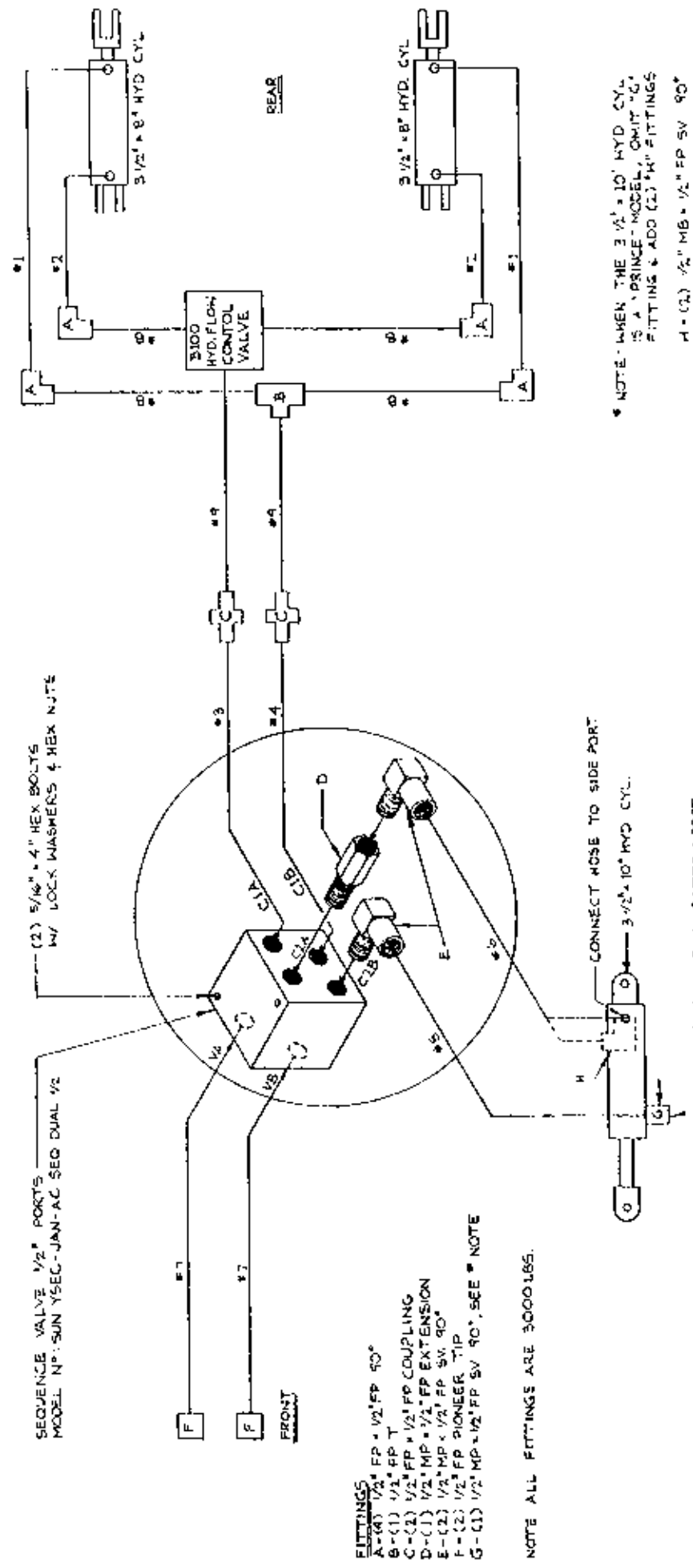

SEQUENCE VALVE 1/2" PORTS
MODEL N°: SUN YSEC - JAN - AC SEQ DUAL 1/2"
(2) 5/16" x 4" HEX BOLTS
W/ LOCK WASHERS & HEX NUTS

- FITTINGS**
 A - (4) 1/2" FP x 1/2" FP 90°
 B - (1) 1/2" FP T
 C - (2) 1/2" FP x 1/2" FP COUPLING
 D - (1) 1/2" MP x 1/2" FP EXTENSION
 E - (2) 1/2" MP x 1/2" FP SV 90°
 F - (2) 1/2" FP PIONEER TIP
 G - (1) 1/2" MP x 1/2" FP SV 90°, SEE * NOTE

NOTE ALL FITTINGS ARE 3000 LBS.

* NOTE - WHEN THE 3 1/2" x 10" HYD. CYL.
IS A PRINCE - MODEL, OMIT "G"
FITTINGS & ADD (2) "H" FITTINGS
H - (2) 1/2" MB x 1/2" FP SV 90°

- HOSES**
 * 1 - (2) 1/2" MP x 1/2" MP SV 41" LONG
 * 2 - (2) 1/2" MP x 1/2" MP SV 33" LONG
 * 3 - (1) 1/2" MP x 1/2" MP SV 33" LONG
 * 4 - (2) 1/2" MP x 1/2" MP SV 36" LONG
 * 5 - (1) 1/2" MP x 1/2" MP SV 52 1/2" LONG
 * 6 - (1) 1/2" MP x 1/2" MP SV 41" LONG
 * 7 - (2) 1/2" MP x 1/2" MP SV 194" LONG

NOTE ALL HOSES ARE 1/2" Ø

- PIPE LINES**
 * 8 - (4) 1/2" Ø x 36" LONG PIPE (A10-4)
 * 9 - (2) 1/2" Ø x 204" LONG PIPE (A10-3 SUBTRACT 48")

NOTE: HOSE LENGTHS ARE FROM END OF THIRD
END OF THIRD

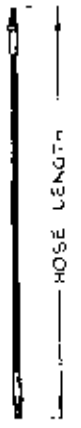

SCHMEISER LAND LEVELER	
SCALE: NONE	APPROVED BY:
DATE: 5/2/95	DRAWN BY: R. JACOBY
HYDRAULIC CYLINDER DIAGRAM	
DRAWING NUMBER SLP-B-HCD	

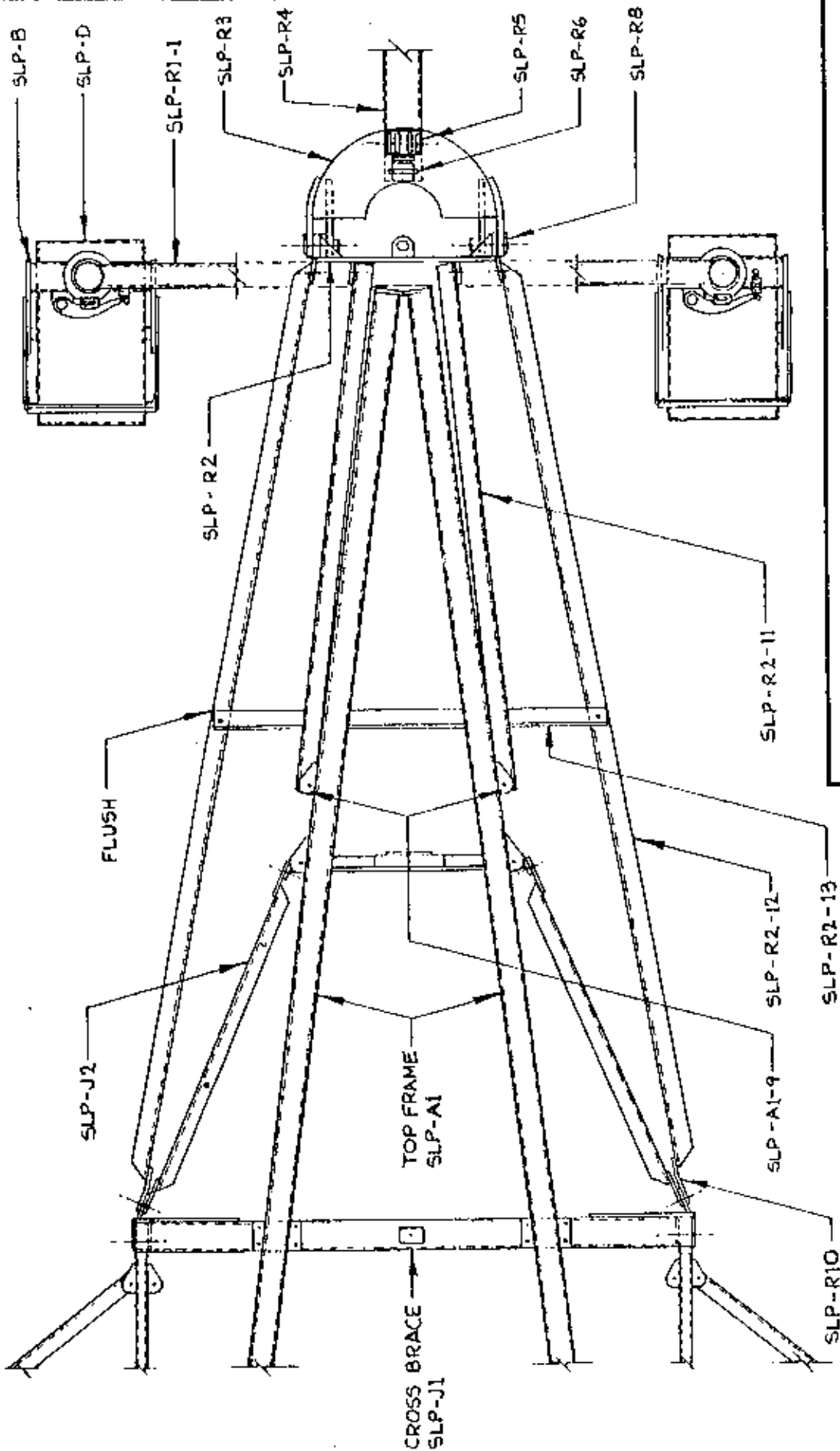

SCHMEISER LAND LEVELER

SCALE: 1/2" = 1'-0"	APPROVED BY:	DRAWN BY M. JACOBY
DATE: 10/30/91		REVISED 9/24/93

QUAD PLANE ~ TOP VIEW, TIE BAR PLACEMENT

BOLT UP ASSEMBLY	DRAWING NUMBER
	SLP-R-TIE

NOTE: DTL5, R1-2 TO R1-11 NOT SHOWN FOR CLARITY

NOTE: LOOSE LINKAGE = R7-1 TO R7-4 D HYD PIPE LINE = R9-1

T.G. SCHMEISER CO., INC.

Limited Warranty Statement

T. G. Schmeiser Co., Inc. warrants each new Schmeiser product to be free from defects in material and workmanship. This warranty is applicable only for the normal service life expectancy of the product or components, not to exceed twelve (12) consecutive months from the date of delivery of the new Schmeiser product to the original purchaser.

Genuine T. G. Schmeiser Co., Inc. replacement parts and components will be warranted for 365 days from date of purchase, or the remainder of the original equipment warranty period, whichever is longer.

Under no circumstances will it cover any merchandise or components thereof, which, in the opinion of the company, has been subjected to misuse, unauthorized modifications, alteration, an accident or if repairs have been made with parts other than those obtainable through T. G. Schmeiser Co., Inc.

The Company in no way warrants engines, batteries, cylinders, tires or other trade accessories since these items are warranted separately by their respective manufacturer. Expendable components such as points, shanks, blades, rings, bearings, teeth, and the like are excluded from this warranty.

Our obligation under this warranty shall be limited to repairing or replacing, free of charge to the original purchaser, any part that, in our judgment, shall show evidence of such defect, provided further that such part shall be returned within thirty (30) days from date of failure to T. G. Schmeiser Co., Inc., routed through the dealer and distributor from whom the purchase was made, transportation charges prepaid.

This warranty shall not be interpreted to render T. G. Schmeiser Co., Inc. liable for injury or damages of any kind or nature to person or property. This warranty does not extend to the loss of crops, loss because of delay in harvesting, or any expense or loss incurred for labor, substitute machinery, rental or for any other reason.

Except as set forth above, T. G. Schmeiser Co., Inc. shall have no obligation or liability of any kind on account of any of its equipment and shall not be liable for special or consequential damages. T. G. Schmeiser Co., Inc. makes no other warranty, expressed or implied, and, specifically, T. G. Schmeiser Co., Inc. disclaims any implied warranty or merchantability or fitness for a particular purpose. Some states or provinces do not permit limitations or exclusions of implied warranties or incidental or consequential damages, so the limitations or exclusion in this warranty may not apply.

This warranty is subject to any existing conditions of supply, which may directly affect our ability to obtain materials or manufacture replacement parts.

T. G. Schmeiser Co., Inc. reserves the right to make improvements in design or changes in specifications at any time, without incurring any obligation to owners of units previously sold.

No one is authorized to alter, modify or enlarge this warranty nor the exclusion, limitations and reservations.